

Basic Specifications

| | | |
|--|---|----------------|
| Capacity | 100Ah@0.2C Discharge | |
| Voltage | 3.2V | |
| Standard charge current | 0.2C | |
| Rapid charge current | 0.5C | |
| Standard Charging method | 0.2C CC(constant current) charge to 3.65V, then CV(constant voltage 3.65V) charge till charge current decline to $\leq 0.05C$ | |
| Charging time | Standard charge: 5 hours (Ref.) Rapid charge: 2 hours (Ref.) | |
| Max. charge current(safe) | 1C | |
| Max. discharge current(safe) | 1C | |
| Max.charge/discharge pulse current (10s) | 5C (10S) | |
| Discharge cut-off voltage | 2.0V \pm 0.15V | |
| Charge voltage | DC 3.65V | |
| Cycle life(0.2C discharge) | \geq 2000 cycles(80%DOD) | |
| Initial Impedance | \leq 1m Ω | |
| Battery Weight | Approx.2.45Kg | |
| Working | Charging | 0°C ~ +45°C |
| | Discharging | -20°C ~ +55°C |
| Storage Temperature | -10°C ~ +45°C | |
| Dimension | Thickness | 20 \pm 0.5mm |
| | Width | 310 \pm 2 mm |
| | Length | 230 \pm 2 mm |

Dimensions :

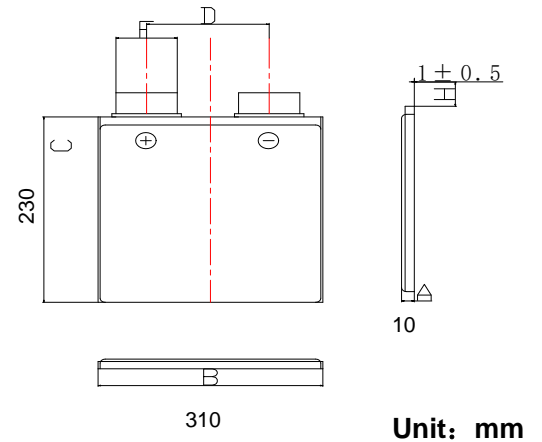

Notice for Assembling Battery Pack

● Tab connection

Ultrasonic welding or spot welding is recommended to connect battery with PCM or other parts.

If apply manual solder method to connect tab with PCM below notice is very important to ensure battery performance.

- 1) The solder iron should be temperature controlled and ESD safe.
- 2) Soldering temperature should not exceed 350°C.
- 3) Soldering time should not be longer than 3s.
- 4) Soldering times should not exceed 5 times.
- 5) Keep battery tab cold down before next time soldering.
- 6) Directly heat cell body is strictly prohibited Battery maybe damaged by heat above approx 100°C.

● Cell fixing

- 1) The battery should be fixed to the battery pack by its large surface area.
- 2) No cell movement in the battery pack should be allowed.

Manufacturer reserves the right to alter or amend the approval sheet without the prior notice